

Tool Heads

Cutting and Drawing Head Type C2 / C2P

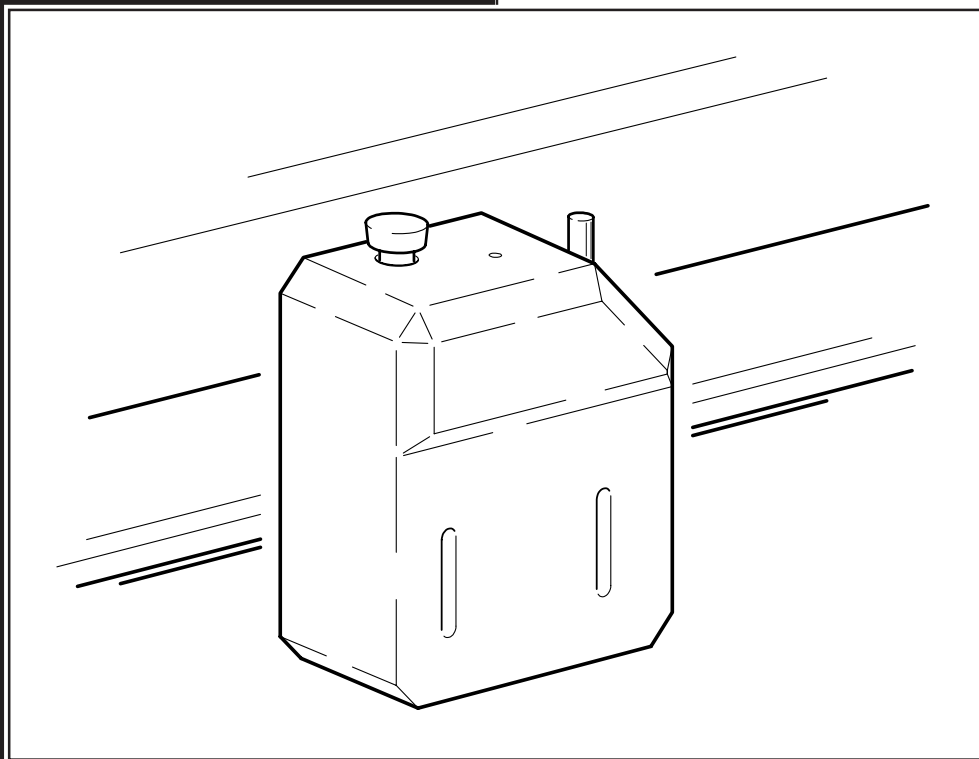

Designation Operating Instructions for Tool Heads
Cutting and Drawing Head, Type C2/C2P
Edition 9809-1

Execution This manual may only be used together with the Operating Instructions
for the PN Modular Plotter System, edition 9809-1.

Composition and illustration Dogrel AG, St. Margrethen

Copyright No part of this publication may be reproduced, transmitted, translated
into another language, converted into an electronic form or stored in a
data processing system as a whole or in parts, without the written
permission of the manufacturer.

© Copyright by Zünd Systemtechnik AG
9450 Altstätten, Switzerland
All rights reserved.

Contents

1. Description of the Cutting and Drawing Head	3-2
1.1 General view	3-2
1.2 Design and function	3-2
1.3 Purpose of use	3-3
2. Technical Data	3-4
2.1 Dimensions	3-4
2.2 Emissions	3-4
2.3 Performance characteristics	3-4
3. Safety Regulations	3-5
3.1 General	3-5
3.2 Danger zones	3-5
3.3 Safety and monitoring devices	3-6
3.4 Protective equipment	3-6
4. Installation	3-7
4.1 Mounting/dismounting	3-7
4.2 Insert/replace tools	3-8
4.2.1 Prepare knife holder	3-8
4.2.2 Prepare pen holder	3-9
4.2.3 Prepare insert sleeve	3-10
4.2.4 Insert tools into cutting/drawing head	3-10
4.2.5 Remove tools from cutting/drawing head	3-12
5. Operation	3-13
5.1 Adjust cutting depth	3-13
5.2 Set cut off pressure	3-14
5.3 Set drawing tools	3-14
5.4 Adjust insert sleeve	3-14
5.5 Checks before starting production	3-15
5.6 Failures	3-15
6. Care and Maintenance	3-16
6.1 Cleaning instructions	3-16
6.2 Maintenance	3-16
7. Accessory	3-17
7.1 Supplied accessory equipment	3-17
7.2 Available tools	3-17
7.2.1 Special knife holder with sliding sleeve	3-17

1. Description of the Cutting and Drawing Head

1.1 General view

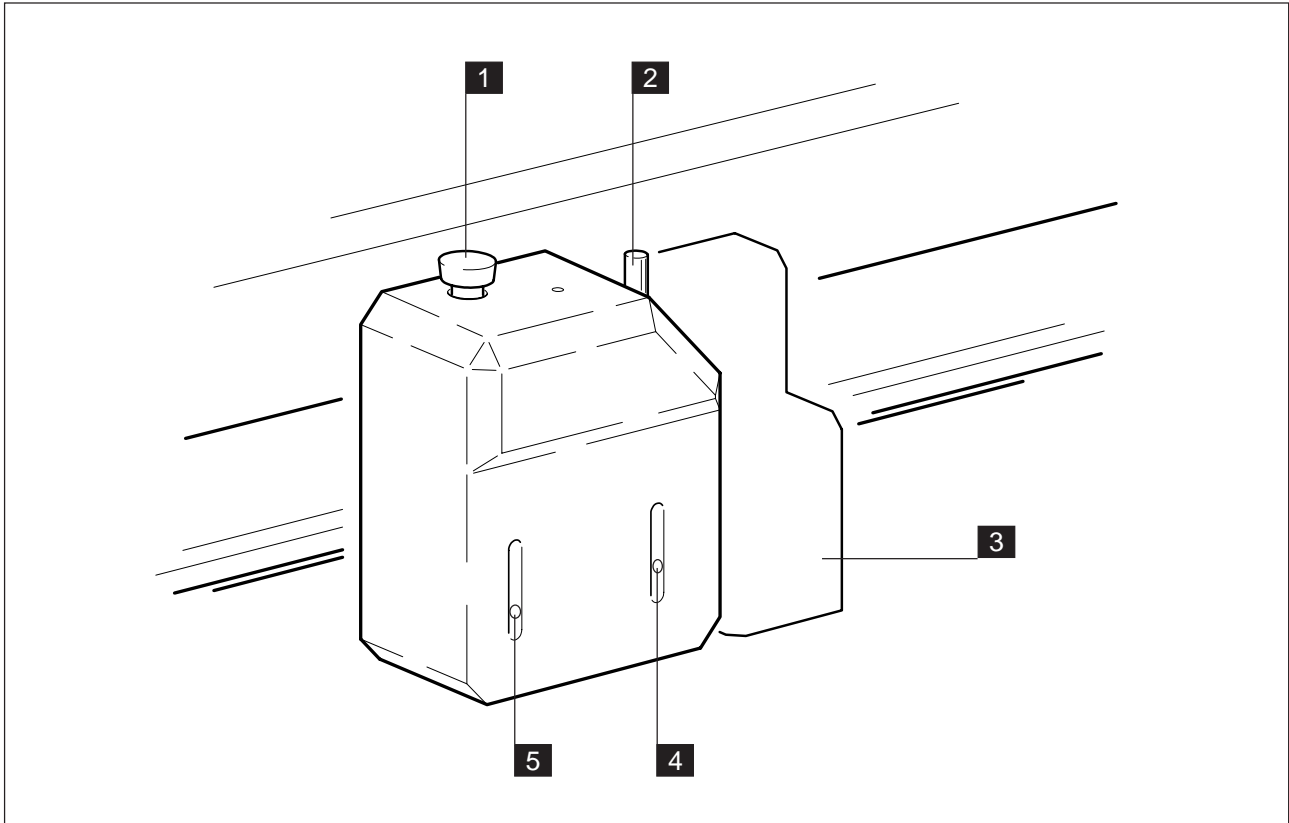

- | | |
|--|-------------------------|
| 1 Height adjustment | 4 Central locking screw |
| 2 Knife holder / Pen holder | 5 LED |
| 3 Drawing module for type C2P (optional) | |

1.2 Design and function

The cutting and drawing head
 - is suitable for all tool plotters of the PN family,
 - supports the integrated cut-off function of the tool plotters.

The cut-off function enables a command-controlled cutting of foils.

Using a central locking screw the cutting and drawing head can be fixed on the head carriage. For this purpose, the required Allen key can be found in the accessory case.

Into the tangentially controlled module of cutting and drawing head
 - a knife holder with knife or
 - a pen holder with ballpoint
 can be inserted.

Using the height adjustment the inserted tool can be

- lowered to the table surface,
- exactly positioned using an LED as a setting help,
- adjusted to the material to be processed.

During initialisation of the plotter system

- a check which tool system is installed,
- an adaptation of the command menu to the cutting and drawing head is carried out.

The inserted tool

- is lowered to the table surface with a defined pressure,
- is turned by default angle values by the tangentially controlled module.

1.3 Purpose of use

Intended use The cutting and drawing head, type C2/C2P is designed for

- cutting of:
 - adhesive foils
 - masking tapes
 - reflecting foils
 - rubber templates for sand-blast masks
- drawing onto different materials using:
 - ballpoints
 - Ball-Pentel (type C2P)
 - ink inserts (type C2P)

Any other or further use is considered to be non-intended use. Zünd is not liable for any damage resulting from such non-intended use; the risk is borne by the user alone!



For special applications of the cutting and drawing head please first consult first

- your Zünd representative,
- the responsible product managers of the manufacturer.

Non-intended use If using the system non-intended

- health hazards and injuries,
- damage to the plotter system,
- damage to the material to be processed and other material damage,
- incorrect functions of the plotter system can be the result.

So avoid:

- Putting the cutting and drawing head into operation without adequate training or without reading the Instruction Manual.
- Careless and irresponsible handling on the cutting and drawing head during ON-LINE operation.
- Carrying out conversions or changes to the cutting and drawing head without permission by the manufacturer.
- Using tools, accessories or spare parts from other suppliers without permission by the manufacturer.

2. Technical Data

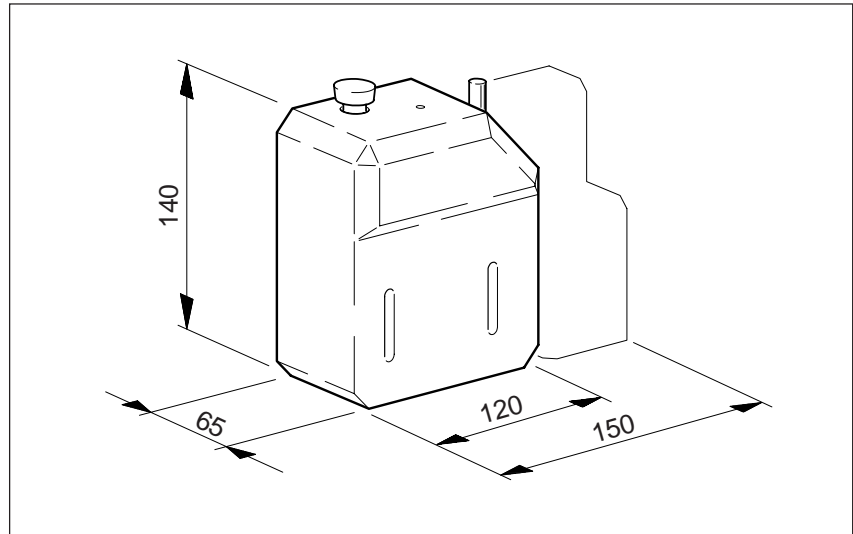

Dimensions in mm

2.1 Dimensions

	Cutting/drawing head Type C2	Cutting/drawing head Type C2P
Overall dimensions (WxLxH)	approx. 120 x 140 x 65 mm	approx. 150 x 140 x 65 mm
Material clearance	25 mm	25 mm

2.2 Emissions

There are no appreciable emissions by the cutting and drawing head, the permissible materials and the drawing/cutting tools.

2.3 Performance characteristics

Adjustable cutting pressure 25 - 1500 g

Height adjustment with electronic monitoring



Accuracy, speed and acceleration depending on

- type of tool plotter,
- set parameters,
- inserted tool,
- material to be processed.

Materials which can be processed

- Ideal for cutting are:
- adhesive foils and reflecting foils,
 - masking tapes,
 - rubber templates for sand-blast masks,
 - thin materials up to approx. 300 g/m²

3. Safety Regulations

3.1 General

Valid are all safety rules specified under register 2 "Tool plotter", section 3.



CAUTION

Sharp-edged cutting tools on the cutting/drawing head.

Possible hazards:

- cuts and stab wounds on fingers and hands.

Precautions:

- Before each replacement of the tool head on the plotter remove tool holder.
- Handle cutting tools carefully during insertion/removal.
- Keep not used cutting tools in their package.



CAUTION

Install/remove cutting and drawing head on the tool plotter.

Possible hazards:

- Damage to the cutting/drawing head and to the head carriage.

Precautions:

- Use cutting/drawing head carefully.
 - During installation, pay attention to the correct centering of the head carriage and tighten central locking screw carefully.
 - During dismounting, remove cutting/drawing head carefully from the head carriage and store it dust-protected.

3.2 Danger zones

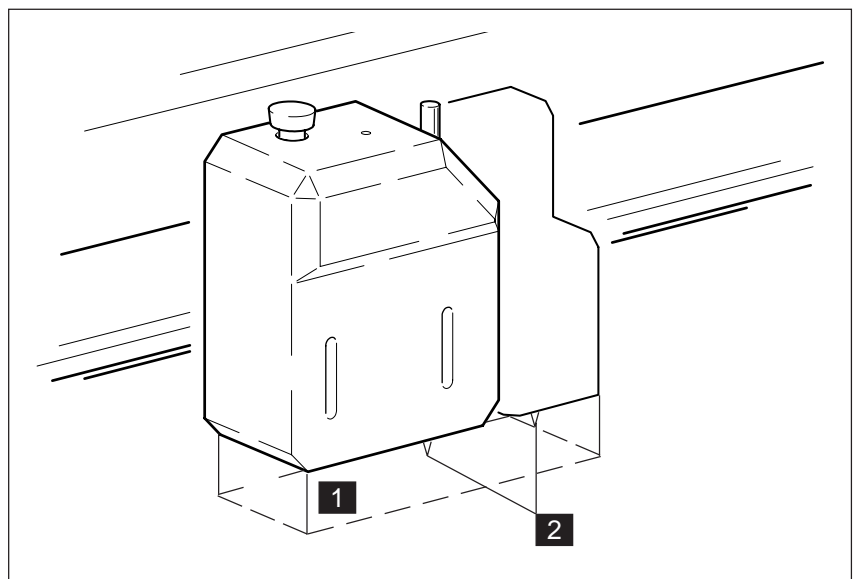

Danger zones of cutting/drawing head

- 1 Area between head and working surface
- 2 Tools

3.3 Safety and monitoring devices

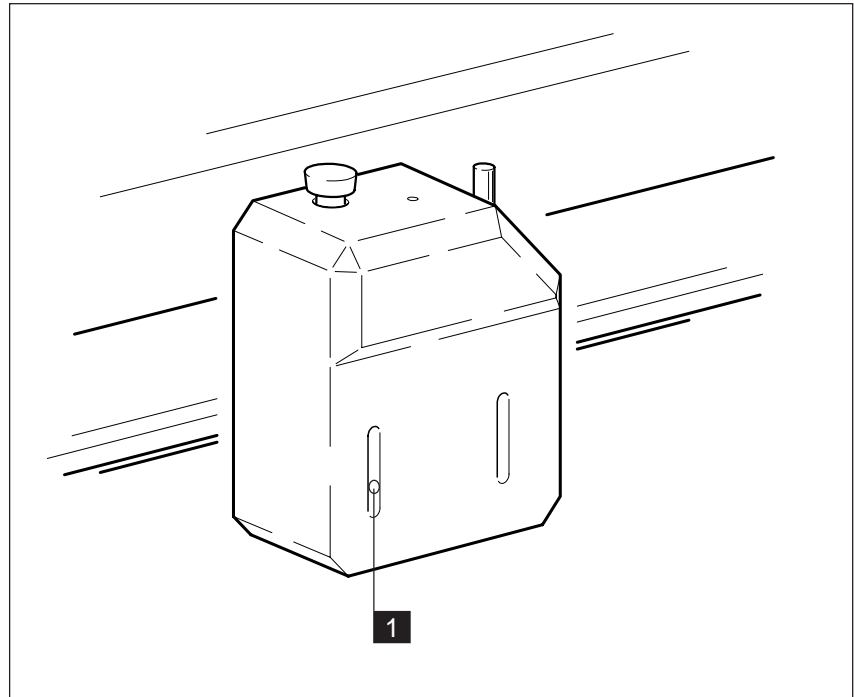

Safety and monitoring devices on cutting/drawing head

1 LED for height adjustment

No special safety devices are available on the cutting and drawing head.

3.4 Protective equipment

No protective equipment is needed for the cutting and drawing head.

Please pay attention to the recommendations in register 2 "Basic Plotter", section 3.4.

4. Installation

4.1 Mounting/ dismounting

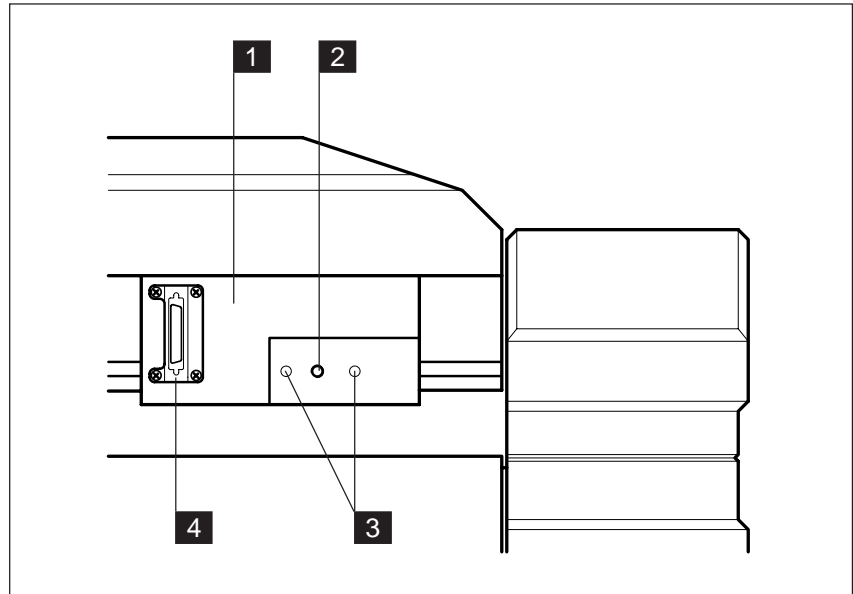

Head carriage on tool plotter

- | | |
|------------------------------------|------------------|
| 1 Head carriage | 3 Centering |
| 2 Thread for central locking screw | 4 D-plug contact |



IMPORTANT

Mount/remove cutting and drawing head only when tool plotter is switched off!

Only during initialization the plotter system identifies the type of used tool head.

Mounting

- Move beam and head carriage of the tool plotter into a suitable position.
- Place cutting/drawing head carefully onto the head carriage and align it until centering and housing of connector are matching.
- Tighten central locking screw carefully using Allen key, 4mm size.



Find the Allen key in the supplied accessory case of the tool system.

Dismounting

- First remove the previous cutting tool. For this purpose, refer to the following section 4.2 "Insert/replace tools".
- Switch off tool plotter.
- Loosen central locking screw using Allen key.
- Carefully remove cutting/drawing head from head carriage.

4.2 Insert/replace tools

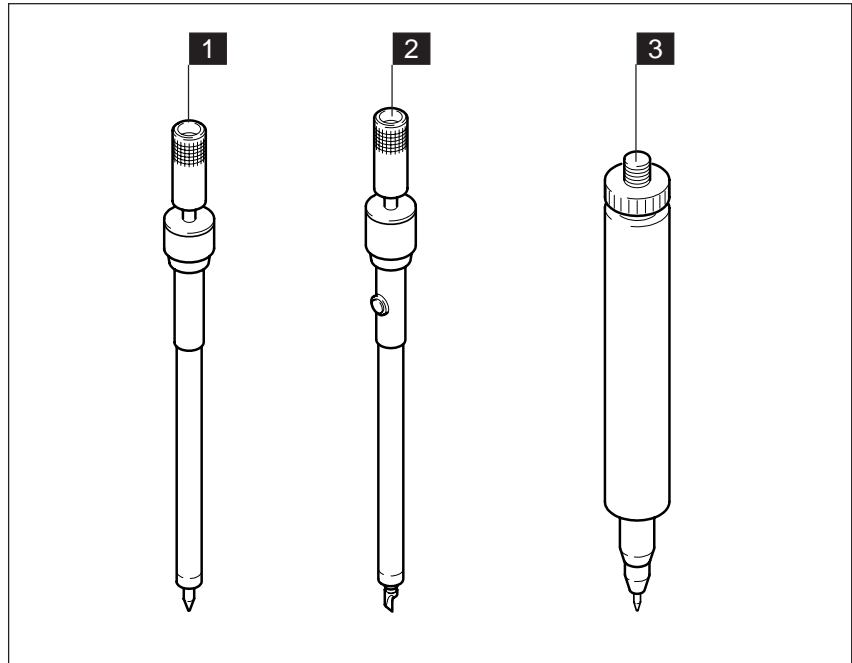

Available inserts

- 1 Pen holder
- 2 Knife holder

- 3 Insert sleeve
(optional for type C2P)

Into the tangentially controlled module of the cutting and drawing head you can insert

- a knife holder for accepting cutting tools,
- a pen holder for accepting ballpoints.

Different insert sleeves can be used with the drawing module of the cutting/drawing head, type C2P (ref. to plotter accessories under register 5 "Accessories").

4.2.1 Prepare knife holder

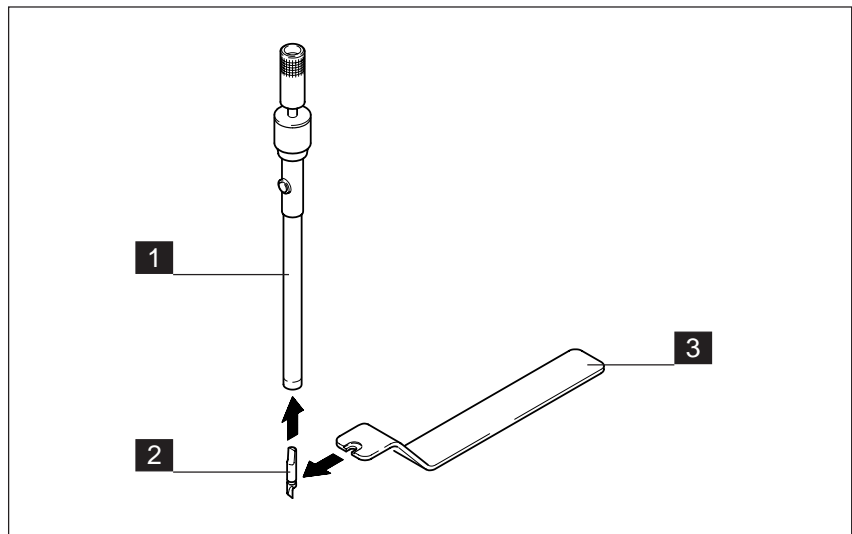

Insert knife into knife holder

- 1 Knife holder
- 2 Knife

- 3 Knife removing device

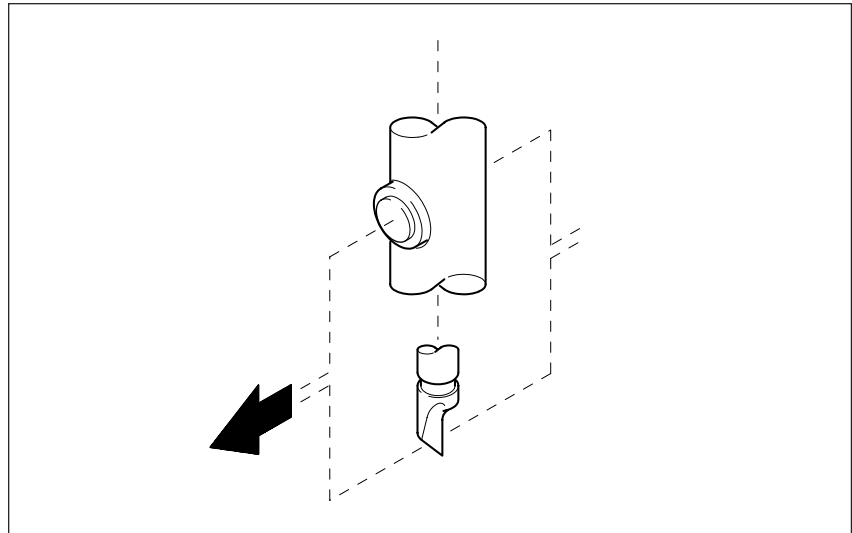

Alignment of knife point

Procedure:

- Place knife removing device into groove of cutting tool.
- Insert cutting tool into the knife holder and turn until it is engaged (ref. to fig.).
- Press in cutting tool into knife holder completely and remove knife removing device.
- For removal, place knife removing device into groove of cutting tool and pull out cutting tool from knife holder.

4.2.2 Prepare pen holder

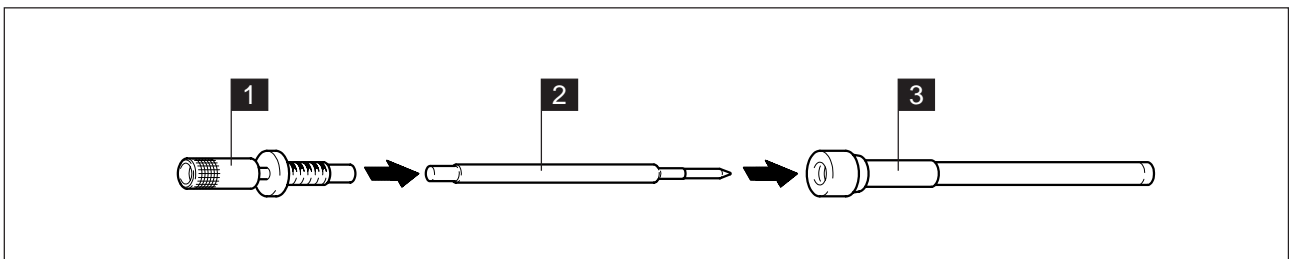

Pen holder dismantled

- 1 Knurled screw
- 2 Ballpoint

- 3 Ballpoint holder with spring

The ballpoint is supported in the pen holder. Using the knurled screw the spring load and as a result the pressure of the ballpoint to the drawing material can be regulated.

Procedure:

- Loosen knurled screw from pen holder.
- Insert desired ballpoint into pen holder.
- Tighten knurled screw on pen holder and adjust pressure.

4.2.3 Prepare insert sleeve

Insert sleeve

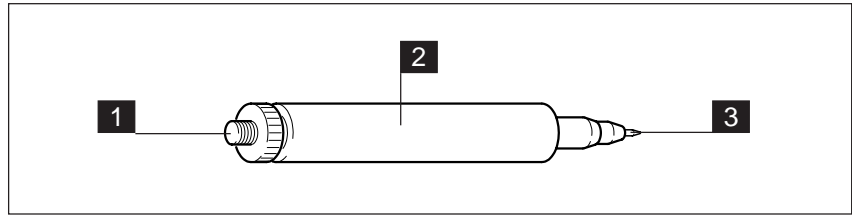

- 1 Knurled screw
- 2 Sleeve with spring
- 3 Drawing tool

Procedure:

- Loosen knurled screw and insert drawing tool.
- Fix knurled screw again and tighten until desired pressure for the drawing tool is reached.



Special insert sleeves are available for

- ballpoints
- pencil leads
- ink tools

4.2.4 Insert tools into cutting/drawing head

Insert tool holder into cutting/drawing head

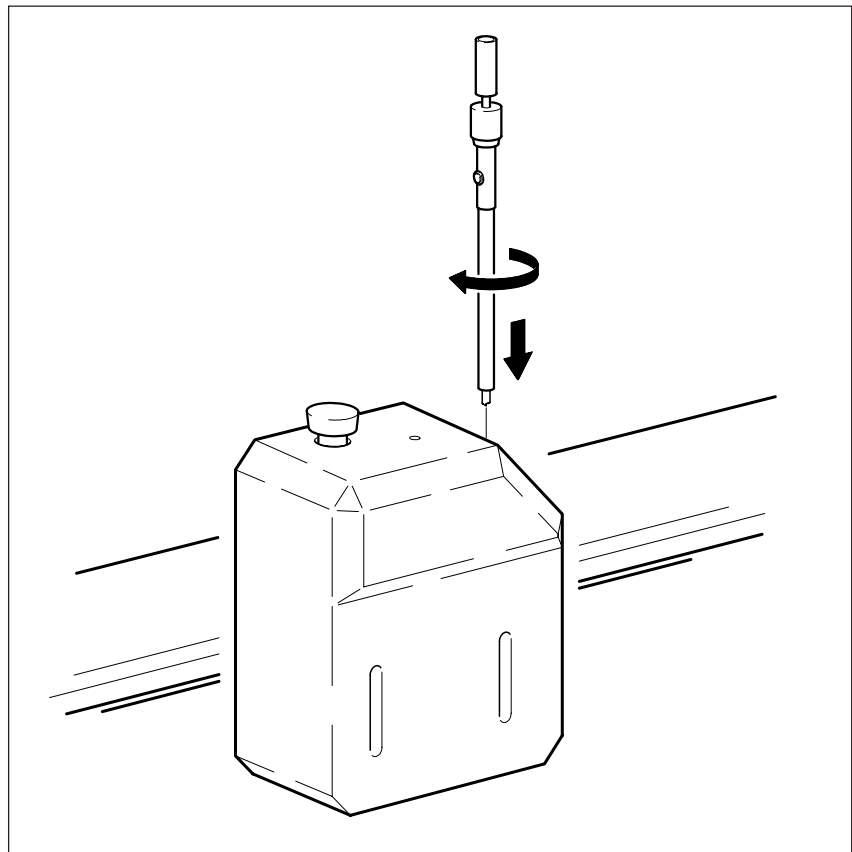

CAUTION
During ON-LINE operation no tools may be inserted into the cutting/drawing head - risk of injury!



Insert tools of cutting and drawing head only in the OFF-LINE mode when tool plotter is switched on.

Procedure for tangentially controlled module:

- Insert knife or pen holder into the tangentially controlled module from above.
- Turn it and press it slightly upwards until engaging.

When inserting into the tangentially controlled module the pen holder and the knife holder are mechanically locked.

Procedure for insert sleeve:

- Select tool no. 2:
Press ESC key.
Enter command 211 via numerical keys.
Enter tool no. 2 eingeben and confirm with ENT-key.

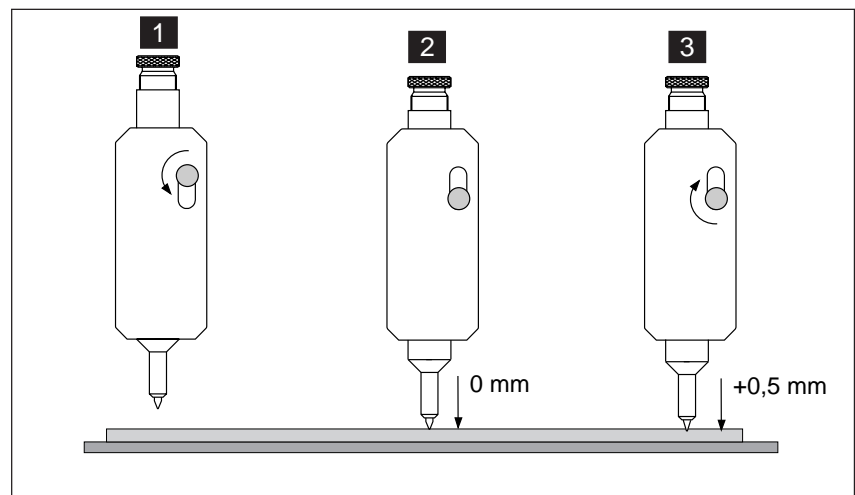

Inserting insert sleeve

1. Loosen clamping screw of drawing head and insert insert sleeve.
2. Lower insert sleeve using key PEN UP/DOWN.
3. Press insert sleeve by hand about 0,5 mm upwards and tighten clamping screw.

4.2.5 Remove tools from cutting/drawing head

**CAUTION**

With switched off tool plotter the tangentially controlled module of the cutting/drawing head remains locked.

If you try to force out the knife or pen holder damage could be the result!

Procedure for tangentially controlled module:

- Switch tool plotter into OFF-LINE operation.
- Press function key F2 on the operator panel or enter command RELEASE PEN (351) and confirm using ENT key.
The locking is released by the tangentially controlled module; knife or pen holder jumps into removal position.
- Pull knife or pen holder out of the cutting/drawing head.

**IMPORTANT**

After pulling out the knife or pen holder no PEN DOWN command via keypad is possible.

When re-inserting a knife or pen holder into the cutting/drawing head first it is necessary to switch into the ON-LINE mode for a short time.

Only on this condition

- an available tool is detected;
- a manual PEN-DOWN command is executed.

5. Operation

5.1 Adjust cutting depth

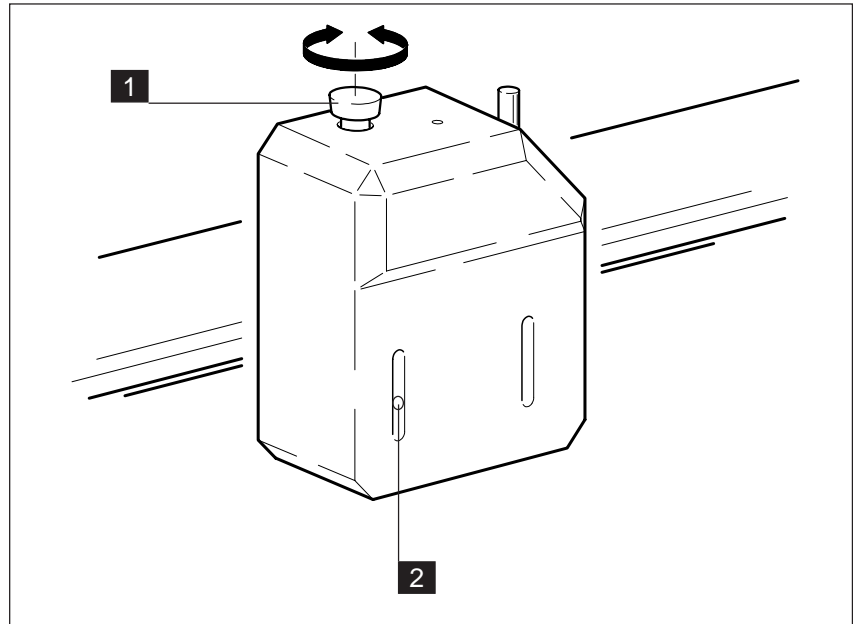

Adjusting devices on cutting/drawing head

1 Height adjustment screw

2 LED

On the tangentially controlled module the optimal cutting depth can be adjusted with the help of a LED.

Preconditions

- The working material is fixed on the table surface.
- The tool plotter is in OFF-LINE mode.
- The cutting/drawing head is near the operator panel for carrying out the following settings.
- The knife is lifted from table.

Procedure:

- Lower the knife to the working material using PEN UP/DOWN key; LED starts flashing.
- Turn height adjustment screw counterclockwise until knife no more touching the working material.
- Slowly turn height adjustment screw clockwise and observe LED:
 - ⇨ LED flashes; faster flashing frequency: setting approaches ideal value.
 - ⇨ LED lights permanently: optimal cutting depth reached.

With this setting a spring deflection for the knife is considered.



In ON-LINE mode vibrations can cause flickering of the LED, but without any influence to the tool setting. If LED is flashing with lowered knife at rest, the cutting depth should be reset.

5.2 Set cut off pressure

The cut off pressure

- can be varied between a range of 25 to 1500 gram.
- is preset to 100 gram.

Procedure:

- Press preset function key F1 on the operator panel or enter command PRESSURE (1161).

KNIFE PRESSURE		
1	↔ KNIFE PRESS.	100
2	CUT OFF PRESS.	500

- Press ENT key.
Now a cursor flashes in the input field CUT PRESS.
- Enter cut off pressure in gram using numerical keys and confirm with ENT key.

5.3 Set drawing tools

Setting for pen holder is carried out in the same way as described under section 5.1 and 5.2.

For particular drawing tools no pressure setting is necessary (e.g. ballpoint).

5.4 Adjust insert sleeve

Adjust contact pressure

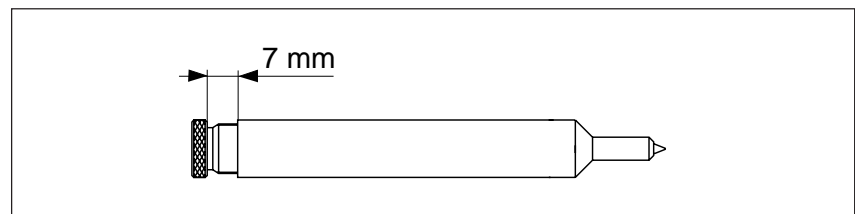

The contact pressure of the drawing tool is adjusted with the knurled screw of the insert sleeve.

The contact pressure should be about 100 gram. This is the obtained when distance between knurled screw and insert sleeve is about 7 mm.

A completely screwed in knurled screw generates a contact pressure of about 300 gram. This value is too high and the lowering of the drawing tool is impeded.

Adjusting tool delays

The lowering characteristic of the drawing tool is directly influenced by the tool delays and should be adapted to the tool (e.g. ink pen).

Tool delays are set
 - in milliseconds,
 - within menu TOOL DELAY (114).

Example for ballpen:

Example for ink pen:

TOOL DELAYS	
1 BEFORE DOWN	0
2 AFTER DOWN	20
3 BEFORE UP	0
4 AFTER UP	20

TOOL DELAYS	
1 BEFORE DOWN	0
2 AFTER DOWN	50
3 BEFORE UP	0
4 AFTER UP	50



If tool delay AFTER DOWN \geq 30 ms the drawing tool is lowered slower.

5.5 Checks before starting production

- On cutting/drawing head
 - the correct tool inserted?
 - cutting depth and cut off pressure correctly set?
- SETUP page in plot file correspond with actual tool configuration?
- Objects (tools etc.) still on table surface and side covers?

5.6 Failures

If the knife holder is strongly pressed upwards (by back-up of material, uneven material etc.) the tool plotter is stopped and the following error message is displayed:

ERROR:	304
R-axis override	
press ESC to initialize	

By pressing the ESC key the tool is re-initialized.
 After failure recovery the working cycle can be continued normally.

6. Care and Maintenance

6.1 Cleaning instructions

- Periodically remove all material residues from cutting and drawing head.
- Occasionally clean knife holder and treat subsequently with the oil supplied.
- Pay attention to clean connectors and contacts (free of dust and dirt).
- Occasionally clean cover using a plastic cleaning agent.

**CAUTION**

Don't use aggressive cleaning agents!

Caustic substances and scouring agents can damage plastic covers.

Only blow out connectors or clean them using a dry and fluff-free cloth.

6.2 Maintenance

We recommend to carry out maintenance for the plotter system once per year. Then also the cutting and drawing head is maintained.



The cutting/drawing head may only be maintained and repaired by

- qualified personnel from the manufacturer,
- personnel from Zünd service stations and Zünd representatives specially trained and authorized by the manufacturer.

7. Accessory

7.1 Supplied accessory equipment

For the cutting/plotting head the accessory equipment case contains

- 1 knife removing device
- 5 spare knives

7.2 Available tools



Refer to plotter accessory list under register 5 "Accessories".

7.2.1 Special knife holder with sliding sleeve

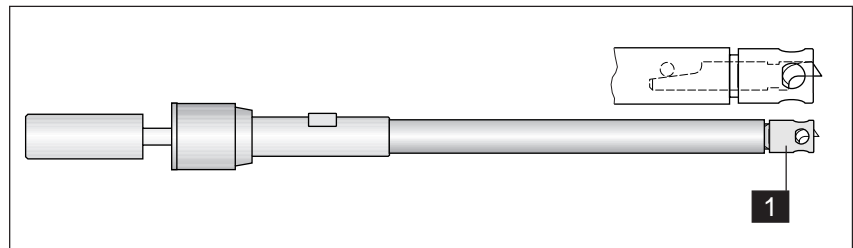





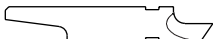

Sliding sleeve

The special knife holder with inserted sliding sleeve (1) keeps constant the cutting depth of the knife. The sliding sleeve follows the material surface and the knife cuts with the preset cutting depth.

Applications:

- Cutting of materials like carton (without carrier foil) on a cutting base.
- Cutting of reflecting foils, e.g. High Grade and Diamond Grade foils.
- Cutting of thick/though materials in connection with the following knife types:

 	Type Z1 - for cutting of thin self-adhesive foils
 	Type Z2 - for cutting of thick foils
 	Type Z4 - for cutting of thin carton or thick foils (Diamond Grade, etc.)

Types of knife

Adjusting the cutting depth:

- Enter cutting pressure with command CUT PRESSURE (1116).



Always adjust cutting pressure
- **before** the cutting depth,
- higher than when cutting without sliding sleeve.

Example: For the Diamond Grade foil the recommended cutting pressure is 1000 - 1500 gram depending on type of knife.

- Pull down two-part slider with O-ring as from knife holder.
- Insert cutting knife into knife holder using the knife removing device.
- Slide sleeve over the cutting knife and put it onto the knife holder until stop.
- Adjust cutting depth by turning the sliding sleeve.

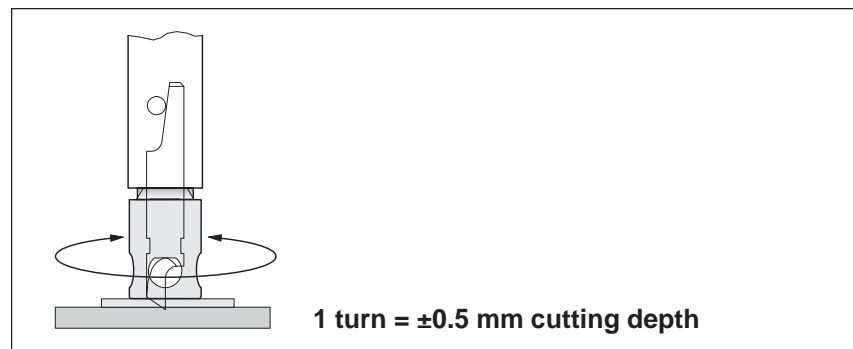

Adjusting cutting depth

Failures:

With very tough materials it is possible that the cutting knife is not penetrating the material at the first lowering even the cutting pressure is correctly adjusted.

In order to adjust the cutting depth nevertheless you must additionally press to the knife holder with a finger.

When cutting Diamond Grade foils the accumulated dust must be able to exit through the openings of the sliding and attachment sleeve.

When adjusting the cutting depth see to it that the holes of the sliding sleeve are situated above the slots of the attachment sleeve.