

Menu Structure

Version: 1

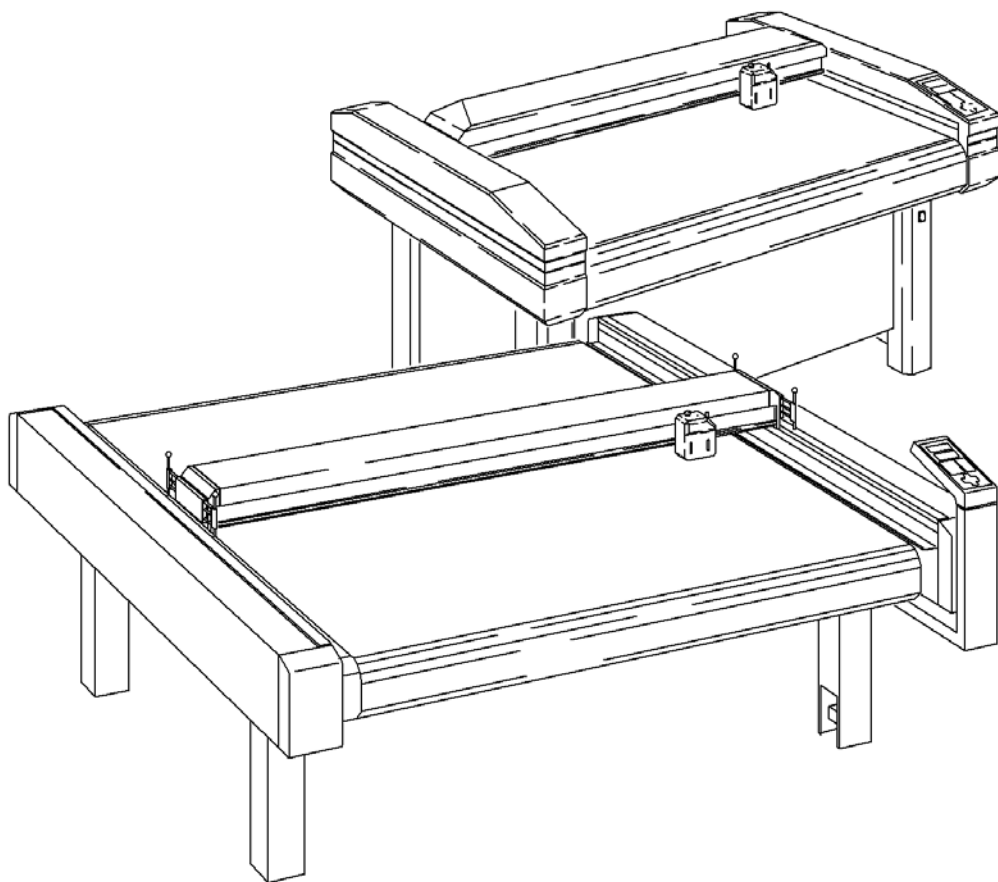

ZÜND 
swiss printing and cutting

(1) JOB SETUP (1)

(1) AXES PARAM (11)

(1) SPEED (111)

- (1) XY-DOWN (1111) U
- (2) XY-UP (1112) U
- (3) MANUAL MOVE (1113)
 - (1) SPEED UP (11131) C
 - (2) SPEED DOWN (11132) C
 - (3) ACCEL (11133) *C
 - (4) BREAK ACCEL (11134) *C
 - (5) SPEED ACCEL (11135) *C

(2) ACCELERATION (112)

- (1) TOOL DOWN (1121) U
- (2) TOOL UP (1122) U

(3) TANGENTIAL (113)

- (1) TANG.ROT (1131)
- (2) LIFTUP ANGLE (1132) U
- (3) TOOL INIT (1133)
- (4) EDGE (1134) *U

(4) TOOL DELAY (114)

- (1) BEFORE DOWN (1141) U
- (2) AFTER DOWN (1142) U
- (3) BEFORE UP (1143) U
- (4) AFTER UP (1144) U
- (5) CONNECT PU/PD (1145) U

(5) Z-AXIS (RzP) (115)

- (1) INIT ABSOLUTE (1151)
- (2) INIT RELATIVE (1152)
- (3) DOWN POS (1153) S
- (4) Z-LOWER (1154) S
- (5) ROUTER ON/OFF (1155)
- (6) VAC.CLEANER (1156)
- (7) UP POS (1157) S
- (8) Z-LIFT (1158) S
- (9) Z-OFFSET (1159) P

(6) KNIFE-PRESSURE(C2) (116)

- (1) CUTTING (1161) U
- (2) CUT OFF (1162) U

(7) PROCESSING (117)

- (1) QUALITY (1171) C
- (2) CONTROL MODE (1172) C

(8) Tz-MODULE (118)

- (1) UP POS (1181) U
- (2) DOWN POS (1182) U
- (3) Z-OFFSET (1183) D
- (4) Z-INIT (1184)
- (5) Z-INIT AUTO (1185)
 - (1) START (11851)
 - (2) ADJUST (11852)
 - (1) OFFSET1 T1 (118521) C
 - (2) OFFSET1 T2 (118522) C
 - (3) OFFSET1 T3 (118523) C
 - (4) OFFSET1 T4 (118524) C
 - (5) OFFSET 0 (118525) P
 - (6) STARTPOS. (118526)
 - (1) X (1185261) P
 - (2) Y (1185262) P
 - (7) DIRECTION (118527) P
 - (8) AKI HAND (118528) P
 - (3) AKI TOOL1 (11853) C
 - (4) AKI TOOL2 (11854) C
 - (5) AKI TOOL3 (11855) C
 - (6) AKI TOOL4 (11856) C
- (6) Z-LOWER (1186) U
- (7) Z-LIFT (1187) U
- (8) MODE (1188) U
- (9) PRESSURE (1189)
 - (1) PRESSURE XY (11891) U
 - (2) PRESSURE X (11892) U
 - (3) PRESSURE Y (11893) U

Configuration parameter	C	Plotter parameter	P
Direct input	D	not saveable	-
User paramter	U	only available in service mode	*

(2) PAGING (12)

- (1) LENGTH (121) C
- (2) VAC DELAY [s] (122) C
- (3) FEEDER (123)
 - (1) FEEDER 1 (1231) S
 - (2) FEEDER 2 (1232) S
 - (3) FEEDER 3 (1233) S
 - (4) FEEDER 4 (1234) S
- (4) LIGHTBARRIER (124) C
- (5) QUICK CONFIG (125)
 - (1) TOGGLE CONFIG (1251)
 - (2) TRANS. CONFIG 1 (1252)
 - (1) LOAD (12521)
 - (2) SAVE (12522) D
 - (3) TRANS. CONFIG 2 (1253)
 - (1) LOAD (12531)
 - (2) SAVE (12532) D
- (6) SHEET FEEDER (126)
 - (1) MODE (1261) C
 - (2) DELAY (1262) C
 - (3) LB LOCK DIST (1263) C
 - (4) LOCK FEEDER (1264) C
- (7) ROLL-OFF-D (127) C
- (8) MODE (128) U
- (9) TRANSPORT (129)
 - (1) ROLL-OFF (1291) C
 - (2) SENSORS (1292) C
 - (3) FIXING (1293) C
 - (4) ROLL-UP (1294) C

(3) ZOOM FACTORS (13)

- (1) ZOOM X,Y (131) U
- (2) ZOOM X (132) U
- (3) ZOOM Y (133) U

(4) GEOMETRY (14)

- (1) ROTATION (141)
 - (1) ADJUST ANGLE (1411)
 - (2) ANGLE (1412) C
 - (3) ROTATION PT. (1413)
 - (1) ADJUST PT. (14131)
 - (2) X-POSITION (14132) C
 - (3) Y-POSITION (14133) C
 - (4) ENABLE (1414)
- (2) OFFSET (142)
 - (1) X-OFFSET (1421)
 - (2) Y-OFFSET (1422)

Configuration parameter	C	Plotter parameter	P
Direct input	D	not saveable	-
User paramter	U	only available in service mode	*

(2) TOOL (2)

(1) SELECT TOOL (21)

- (1) TOOL NR (211) S
- (2) LOCK TOOL (212) S

(2) TOOL SETUP 1 (22)

- (1) ROUTER (221)
 - (1) CONV.TYPE (2211) P
 - (2) ROUTER DELAY (2212) P
 - (3) RPM (2213)
 - (4) LINK TO TOOL (2214) U
- (2) OSCILLATING TOOL (222)
 - (1) DELAY (2221) C
 - (2) LINK TO TOOL (2222) U
 - (3) FREQUENCY (2223) C
 - (4) POT + DRT/EOT (2224) C
- (3) LASER (223)
 - (1) FREQUENCY (2231) U
 - (2) POWER DEFINITION (2232)
 - (1) RECESS POWER (22321) U
 - (2) LASER POWER (22322) U
 - (3) MIN.POWER (22323) U
 - (4) TRIM POWER (22324) U
 - (3) IO CONFIG (2233)
 - (1) EXT. PROC. GAS (22331) U
 - (2) EXTERNAL LOCK (22332) U
 - (3) PRESSURE PNEU. (22333) U
 - (4) CONN VAC-HOV. (22334) C
 - (5) WRN LMP FLASH (22335) C
 - (6) ERR LMP FLASH (22336) C
 - (7) RDY LMP FLASH (22337) C
 - (8) FLASH TIME (22338) C
 - (4) EXHAUST DLY (2234) U
 - (5) OPTION (2235) *C
 - (6) PWR SCALING (2236) *C
 - (7) LASERTYPE (2237) *C
 - (8) LASERMODE (2238) *C
 - (9) SHUTTER (2239) *C
- (4) PASSEPARTOUT (224)
 - (1) DELAY (2241) C
 - (2) LINK TO TOOL (2242) U
- (5) CUTTING TOOL (225)
 - (1) WIDTH (2251) S
- (6) PRESSURE SWITCHING (226)
 - (1) LINK TO TOOL (2261) U
- (7) JETPLOT (227)
 - (1) LINK TO TOOL (2271) U
- (8) SPEC. PENPULS (228)
 - (1) LINK TO TOOL (2281) U
- (9) DISTANCE COUNTER (229)
 - (1) LINK TO TOOL (2291) C
 - (2) ACTUAL (2292) D
 - (3) MAXIMUM (2293) D

(3) TOOL SETUP 2 (23)

- (1) DRT (231)
 - (1) DELAY (2311) C
 - (2) LINK TO TOOL (2312) U
 - (3) REVOLUTIONS (2313) C
 - (4) RESERVE (2314)
 - (5) RESERVE (2315)
 - (6) OVERTEMP (2316) *C
 - (7) OVERCURRENT (2317) *C
- (2) NOTCH TOOL (232)
 - (1) PUNCH LEFT (2321) C
 - (2) PUNCH RIGHT (2322) C

Configuration parameter	C	Plotter parameter	P
Direct input	D	not saveable	-
User paramter	U	only available in service mode	*

- (3) T75-MODULE (233)
 - (1) TILT (2331) C
 - (2) ENABLE (2332) C
- (4) GLUE MODULE (234)
 - (1) LINK TO TOOL (2341) U
 - (2) TIME NORMAL (2342) C
 - (3) TIME ADJUST (2343) C
 - (4) GLUE RESERVE (2344)
- (5) PART MARKER (235)
 - (1) LINK TO TOOL (2351) U
 - (2) WIDTH CORR. (2352) C
- (6) CAMERA ILLUM. (236)
 - (1) MODE (2361) C
 - (2) INTENSITY (2362) C
 - (3) RESERVED (2363) C
 - (4) RESERVED (2364) C
 - (5) PWR UP INIT. (2365) C
- (4) CUT PRECISION (24)
 - (1) ADJUST XY (241)
 - (1) X CORRECTION (2411) C
 - (2) Y CORRECTION (2412) C
 - (3) CHECK CUT (2413)
 - (2) ADJUST TANG (242)
 - (1) CHECK CUT (2421)
 - (2) CORR. TOOL 1 (2422) C
 - (3) CORR. TOOL 2 (2423) C
 - (4) CORR. TOOL 3 (2424) C
 - (5) CORR. TOOL 4 (2425) C
 - (3) TEST PATTERN (243)
 - (1) POLYGON (2431)
 - (2) RECTANGLE (2432)
 - (4) ENABLE (244)
 - (1) TOOL 1 (2451) C
 - (2) TOOL 2 (2452) C
 - (3) TOOL 3 (2453) C
 - (4) TOOL 4 (2454) C
- (5) TOOL MANAGER (25)
 - (1) SHOW LOADED TOOLS (251)
 - (2) RECALL SETTING (252)
 - (3) SAVE SETTING (253)
 - (4) SPECIFY NEW TOOL (254)
 - (5) MODE (255)
- (6) Z DOWN LIMIT (26) D

Configuration parameter	C	Plotter parameter	P
Direct input	D	not saveable	-
User paramter	U	only available in service mode	*

(3) FUNCTIONS (3)

(1) TEST-CUT (31)

(2) PAGE / CUT (32)

- (1) PAGE FEED (321)
- (2) CUT (322)
- (3) FEED + CUT (323)
- (4) MANUAL FEED (324)
- (5) EXT. MAN. FEED (325)

(3) BUFFER (33)

- (1) CLEAR BUFFER (331)
- (2) REPLOT (332)

(4) WINDOW (34)

- (1) STATUS (341) (1) WINDOW (3411)
- (2) DEFINE (342)
- (3) SHOW (343)

(5) C2 TOOL (35)

- (1) RELEASE TOOL (351)

(6) STATUS (36)

- (1) SHOW STATUS (361)
- (2) PLOT STATUS (362)

(7) DIGITIZER (37)

(8) TESTS (38)

- (1) PLOTS (381)
 - (1) DIN (3811)
 - (2) POLYGON (3812)
 - (3) RANDOM-LINE (3813)
 - (4) DIAGONAL (3814)
 - (5) RANDOM-CURVE (3815)
 - (6) SQUARE (3816)
 - (7) CIRCLE (3817)
- (2) SYSTEM (382)
 - (1) TESTFUNCTIONS (3821)

(9) MORE (39)

- (1) REFERENCE (391)
 - (1) SET REFERENCE 1 (3911)
 - (2) GO REFERENCE 1 (3912)
 - (3) CLEAR + GO (3913)
 - (4) GOTO XY (3914)
 - (1) GOTO X (39141)
 - (2) GOTO Y (39142)
 - (5) MOVE Y2 (3915)
 - (6) SET REFERENCE 2 (3916)
 - (7) GO REFERENCE 2 (3917)
 - (8) MODE (3918)
 - (1) DBL REF MOD (39181) C
 - (2) POINTER KIND (39182) C
 - (9) TOGGLE REF PT. (3919)
- (2) VACUUM (392)
 - (1) PUMP ON/OFF (3921)
 - (2) VALVE ON/OFF (3922)
 - (3) WIDTH (3923)
 - (4) OFF DELAY (3924)
 - (1) DELAY TIME (39241) C
 - (5) SET VAC (3925)
 - (6) FOILCOVER (3926) C
 - (7) LC16/52 ZONE (3927) C
 - (8) LC2400 ZONES (3928)
 - (1) TOGGLE ZONE (39281)
- (3) MOVE TO PARK (393)
- (4) SELECT TOOL (394)
 - (1) TOOL + (3941)
 - (2) TOOL - (3942)

Configuration parameter	C	Plotter parameter	P
Direct input	D	not saveable	-
User paramter	U	only available in service mode	*

(4) USERS (4)

- (1) RECALL USER (41)
 - (1) USERNUMBER (411)
- (2) SAVE USER (42)
 - (1) USERNUMBER (421)
- (3) SET START USER (43)
 - (1) USERNUMBER (431) C
- (4) SET USERSTRING (44)
 - (1) ENTER TEXT (441) U
- (5) SET FUNCTION KEY (45)
 - (1) F1 KEY (451) U
 - (2) F2 KEY (452) U
 - (3) F3 KEY (453) U
 - (4) F4 KEY (454) U
 - (5) REF KEY (455) P
 - (6) VAC KEY (456) P
- (6) SAVE CONFIG (46)

Configuration parameter	C	Plotter parameter	P
Direct input	D	not saveable	-
User paramter	U	only available in service mode	*

(5) BASIC SETTINGS (5)

(1) SERIAL LINK (51)

- (1) BAUD (511) U
- (2) FORMAT (512) U
- (3) PROTOCOL (513) U
- (4) TERMINAL CHECK (514)
- (5) SCI DIAGNOSTIC (515) C

(2) UNITS (52)

- (1) UNITS (521) C

(3) MODE (53)

- (1) LANGUAGE (531) C
- (2) PARSER (532) C
- (3) RIGHTS (533) S
- (4) LOCK SETTINGS (534) S

(4) L-BARRIER ON/OFF (54) S

(5) SERVICE MODE (55)

- (1) CONFIGURATION (551)

(1) TABLE TYPE (5511)

- (1) MODEL (55111) P
- (2) SAVE PLOTTER (55112)
- (3) OPTION (55113)
 - (1) LASER (551131) P
 - (2) HEAVY HEADS (551132) P
 - (3) COMMON ZERO (551133) P
 - (4) SPEED (551134) P
 - (5) EXTEND. X-AREA (551135) P
 - (6) LOCK DIST LB (551136) P
 - (7) REGISTER PINS (551137) P
 - (8) TURNED KEYBRD (551138) P
 - (9) MORE (551139)
 - (1) NEW VACUUM (5511391) P
 - (2) IMM. PUMP-OFF (5511392) P
 - (3) REPLOT-ONLINE (5511393) P
 - (4) KBD TURNED CCW (5511394) P
- (4) LC27/32DB (55114)
 - (1) TYPE (551141)
 - (2) RI. FOIL POS (551142) P
 - (3) LE. FOIL POS (551143) P
- (5) INT OPTIONS (55115)
 - (1) FEEDER RELEASE (551151) P
 - (2) FF REL (551152) P
 - (3) ADD LF TERM (551153) P
 - (4) OS OUTPUT (551154) P
 - (5) PAGING ZOOM (551155) P
 - (6) RS SYST. STATE (551156) P
 - (7) FRONTEND REPLY (551157) P
 - (8) Tz POS CHECK (551158) P

(2) INIT SEQUENCE (5512)

- (1) FIRST TO +Y (55121) P
- (2) INIT Y FIRST (55122) P

(3) LIGHTBARRIER (5513)

- (1) LIGHTBARRIER 1 (55131) P
- (2) LIGHTBARRIER 2 (55132) P
- (3) LIGHTBARRIER 3 (55133) P
- (4) LB DURING INIT (55134) P
- (5) LOCK DISTANCE (55135)
 - (1) DIST. LOW (551351) P
 - (2) DIST. HIGH (551352) P
- (6) LB AT MANMOVE (55136) P

(4) IDENTIFIK. TEXT (5514)

- (1) OI TEXT (55141) P

(5) SPISLAVES (5515)

- (1) AWV (55151) P
- (2) LX2 (55152) P
- (3) PH800 (55153) P
- (4) 3AXES1 (55154) P
- (5) SHEET FEEDER (55155) P
- (6) Y-BOARD (55156) P

Configuration parameter	C	Plotter parameter	P
Direct input	D	not saveable	-
User paramter	U	only available in service mode	*

- (6) BOARDS (5516)
 - (1) IO-BOARD (55161) P
- (7) LINEAR-ENCODER (5517)
 - (1) X-LIN.ENCODER (55171) P
- (8) ALGORITHMS (5518)
 - (1) SUB HUNDREDTH (55181) P
- (2) LIMITS (552)
 - (1) SIZE (5521)
 - (1) SIZE X (55211) P
 - (2) SIZE Y (55212) P
 - (3) SIZE Z (55213) P
 - (4) SIZE R (55214) P
 - (5) MAX FEEDLEN (55215) P
 - (2) SCALE (5522)
 - (1) SCALE X (55221) P
 - (2) SCALE Y (55222) P
 - (3) SCALE Z (55223) P
 - (4) SCALE R (55224) P
 - (3) OFFSETS (5523)
 - (1) HEAD OFFSETS (55231)
 - (1) H-OFFSET X (552311) P
 - (2) H-OFFSET Y (552312) P
 - (3) PEN2 X (552313) P
 - (4) PEN2 Y (552314) P
 - (5) PEN3 X (552315) P
 - (6) PEN3 Y (552316) P
 - (7) PEN4 X (552317) P
 - (8) PEN4 Y (552318) P
 - (2) Z-OFFSET (55232)
 - (1) OFFSET Z (552321) P
 - (3) POINTER OFFSETS (55233)
 - (1) X-OFFSET (552331) P
 - (2) Y-OFFSET (552332) P
 - (4) TOOL MANAGER (55234)
 - (1) PEN2 Z-OFFSET (552341) P
 - (2) PEN3 Z-OFFSET (552342) P
 - (3) PEN4 Z-OFFSET (552343) P
 - (4) MAX MOVE (5524)
 - (1) MAX SPEED (55241) P
 - (2) MAXSPEED Z (55242) P
 - (3) MAXSPEED R (55243) P
 - (4) MAX ACCEL (55244) P
 - (5) BUFFER (5525)
 - (1) BUF.SIZE[KB] (55251)
 - (6) VAC MOTOR (5526)
 - (1) VAC MOTOR MAX (55261) P
- (3) INTERF. SETTING (553)
 - (1) UNIBOARD (5531)
 - (1) BUMPER (55311) P
 - (2) EMTEC (55312) P
 - (3) JUMBO RO (55313) P
 - (2) 3AXES1 (5532)
 - (1) BUMPER (55321) P
 - (2) FOIL COVER (55322) P
 - (3) SAFE HEAD (55323) P
 - (4) AIR CHECK (55324) P
 - (3) CLEAN OLD (5533)
 - (1) CLEAN ACTIV (55331) P
 - (4) CLEAN NEW (5534)
 - (1) CLEAN ACTIV (55341) P
 - (2) CLEAN END SW (55342) P

Configuration parameter	C	Plotter parameter	P
Direct input	D	not saveable	-
User paramter	U	only available in service mode	*

(4) PAGE (554)

- (1) COMP (5541) P
- (2) PAGESPEED (5542) P
- (3) PAGEACCEL (5543) P
- (4) NEG. FEED (5544) P
- (5) PWMB SCALE (5545) P
- (6) MAN. BRK. ACCEL (5546) P
- (7) AUX.DRV.CONTROL (5547)
 - (1) CONTROL (55471) P
 - (2) DIVISOR (55472) P
- (8) DELAYS (5548)
 - (1) DELAY1 (55481) P
 - (2) DELAY2 (55482) P
 - (3) DELAY3 (55483) P
 - (4) DELAY4 (55484) P

(5) PARK DIST (555)

- (1) PARK X (5551) P
- (2) PARK Y (5552) P

(6) FACTORY MODE (556)

- (1) SERIAL NR (5561)
 - (1) NR (55611) P
- (2) GAIN HIGH (5562)
- (3) I.OPTION (5563) P

(6) PORTAL MOVE BP (56) S

Configuration parameter	C	Plotter parameter	P
Direct input	D	not saveable	-
User paramter	U	only available in service mode	*